

### Description

The BP2866C is a high precision buck constant current LED driver. The device operates in critical conduction mode and is suitable for 85Vac~265Vac universal input offline LED lighting.

The BP2866C integrates a 500V power MOSFET, with patented demagnetization detection technology. High - voltage JFET power supply technology, which can save VCC capacitor and starting resistors, minimize the system cost and size.

The BP2866C utilizes patent pending current control method. It can achieve precise output current and excellent line regulation. The driver operates in critical conduction mode, the output current does not change with the inductance and LED output voltage.

The BP2866C offers rich protection functions to improve the system reliability, including LED short circuit protection, VCC under voltage protection, thermal regulation function.

### Features

- No VCC Capacitor Or Starting Resistance
- Integrated High Voltage Power Supply Function
- No Auxiliary Winding
- Universal Input Voltage
- $\pm 5\%$  LED Output Current Accuracy
- LED Short Protection
- Input Low Voltage Protection
- Thermal Regulation Function
- Available in SOP7 Package

### Applications

- LED Candle Light
- LED Bulb
- Other LED Lighting

### Typical Application

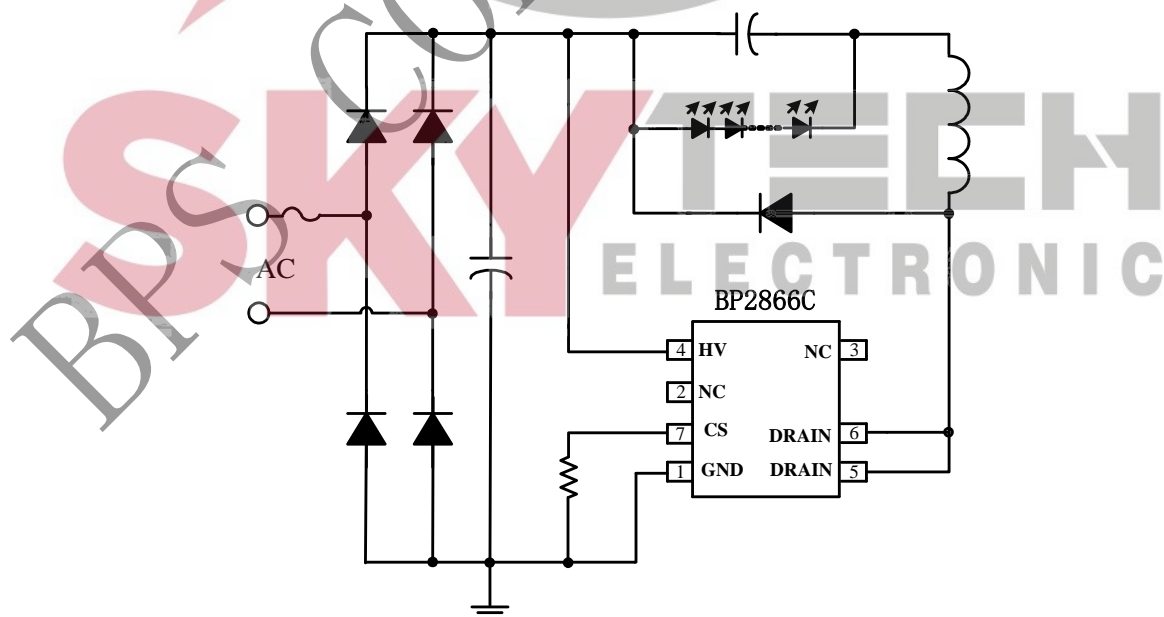

Figure 1. Typical application circuit for BP2866C

**Ordering Information**

Part Number	Package	Operating Temperature	Package Method	Marking
BP2866C	SOP7	-40 °C to 105 °C	Tape 4,000 Piece/Reel	BP2866C XXXXXXYY WXXXYYZ

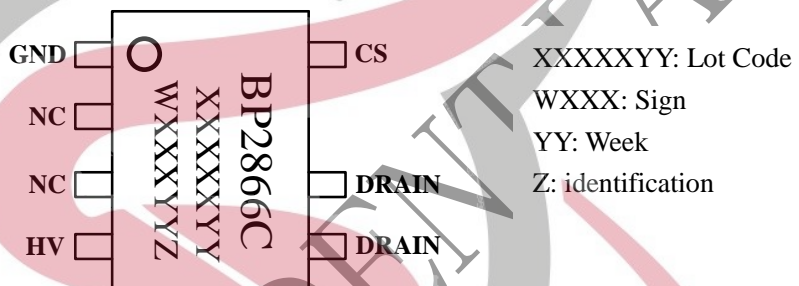
**Pin Configuration and Marking Information**

Figure 2. Pin configuration

**Pin Definition**

Pin No.	Name	Description
1	GND	Ground
2,3	NC	No Connection.
4	HV	High voltage power supply Pin
5,6	DRAIN	Internal HV Power MOSFET Drain.
7	CS	Current Sense Pin. Connect a sense resistor between this pin and GND pin.